

**2 PIECES CARBON STEEL BALL VALVES FLANGED PN 16
PERFORMANCE RANGE**



Certificate 3.1

Size : DN 15 to 300 mm
Ends : PN16/40 R.F. Flanges
Min Temperature : - 20°C
Max Temperature : + 200°C
Max Pressure : 40 Bars up to DN50 (16 bars over)
Specifications : ISO 5211 mounting pad
PTFE filled with 15% glass seat
Anti blow-out stem
Atex
Fire safe according to API607 up to DN200

Materials : Carbon steel ASTM A216 WCB

**2 PIECES CARBON STEEL BALL VALVES FLANGED PN 16
PERFORMANCE RANGE**

SPECIFICATIONS :

- Full bore
- Anti blow-out stem
- Double antistatic device
- PTFE filled with 15% glass seat
- Locking device
- ISO 5211 mounting pad
- 2 pieces type (Split body)
- Hollowed ball from DN125 to DN300
- With exhaust hole in the ball (located in the top of the ball to avoid overpressure in it)
- Primer coating

USE :

- Chemical industries, petrochemical industries, hydraulic installation, compressed air, heating and water distribution
- Steam : 11 bars maximum
- Min and max Temperatures Ts : -20°C to + 200°C
- Max Pressure Ps : 40 bars up to DN50, 16 bars over (see graph under)

PRESSURE / TEMPERATURE GRAPH (STEAM EXCLUDED) :

PRESSURE

(Bar)

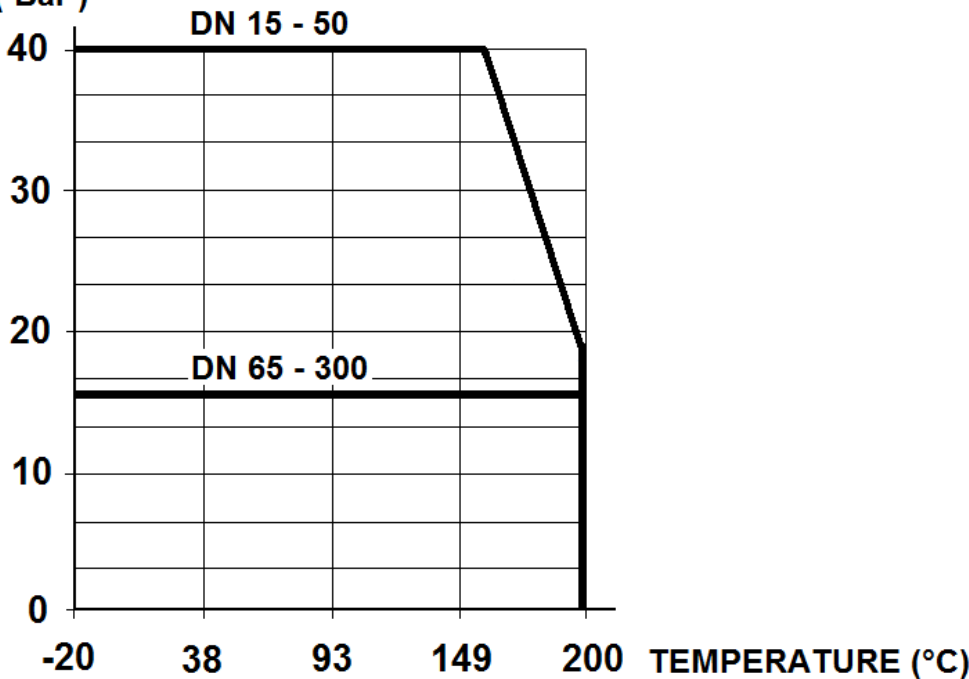

RANGE :

- Carbon steel body ball valve flanged PN16 Ref. 762 from DN 15 to DN 200 (with gearbox from DN250 to 300)
- Gearbox possible Ref. 9830296-9830297 from DN 150 to DN 200

ENDS :

- R.F. Flanged PN40 up to DN50, PN16 over

**2 PIECES CARBON STEEL BALL VALVES FLANGED PN 16
PERFORMANCE RANGE**

MATERIALS DN 15 - 50 :

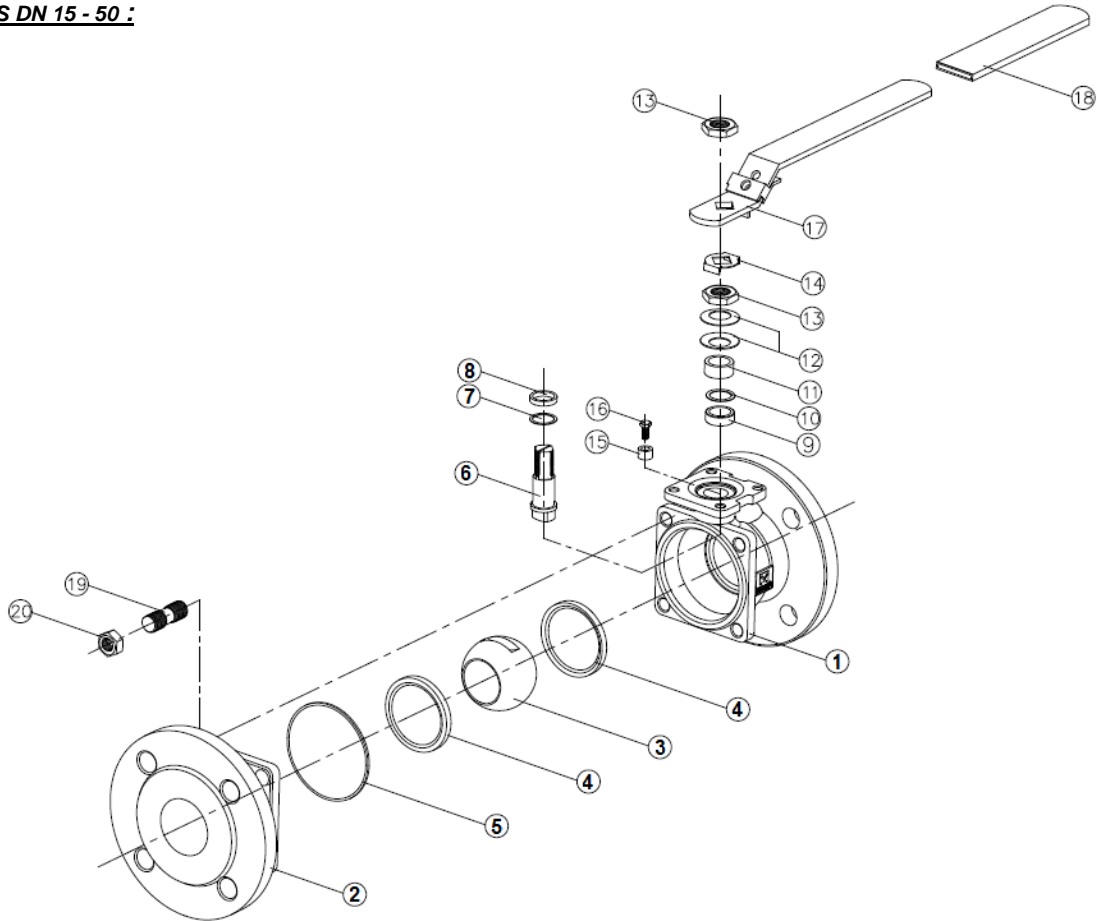

(* : included in gaskets kit)

Item	Designation	Materials
1	Body	ASTM A216 WCB
2	Ends	
3	Ball	ASTM A351 CF8M
4*	Seat	PTFE filled with 15 % glass
5*	Body seal	Graphite
6	Stem	ASTM A276 316
7*	Ring	PTFE filled with 25% carbon
8*	Ring	
9*	Packing	Graphite
10*	Packing	PTFE filled with 25% carbon
11	Packing gland	AISI 304
12	Elastic ring	AISI 301
13	Nut	AISI 304
14	Washer	
15	Pin	
16	Pin screw	
17	Handle	PVC
18	Handle cover	
19	Stud	ASI 304
20	Nut	

**2 PIECES CARBON STEEL BALL VALVES FLANGED PN 16
PERFORMANCE RANGE**

MATERIALS DN 65 - 100 :

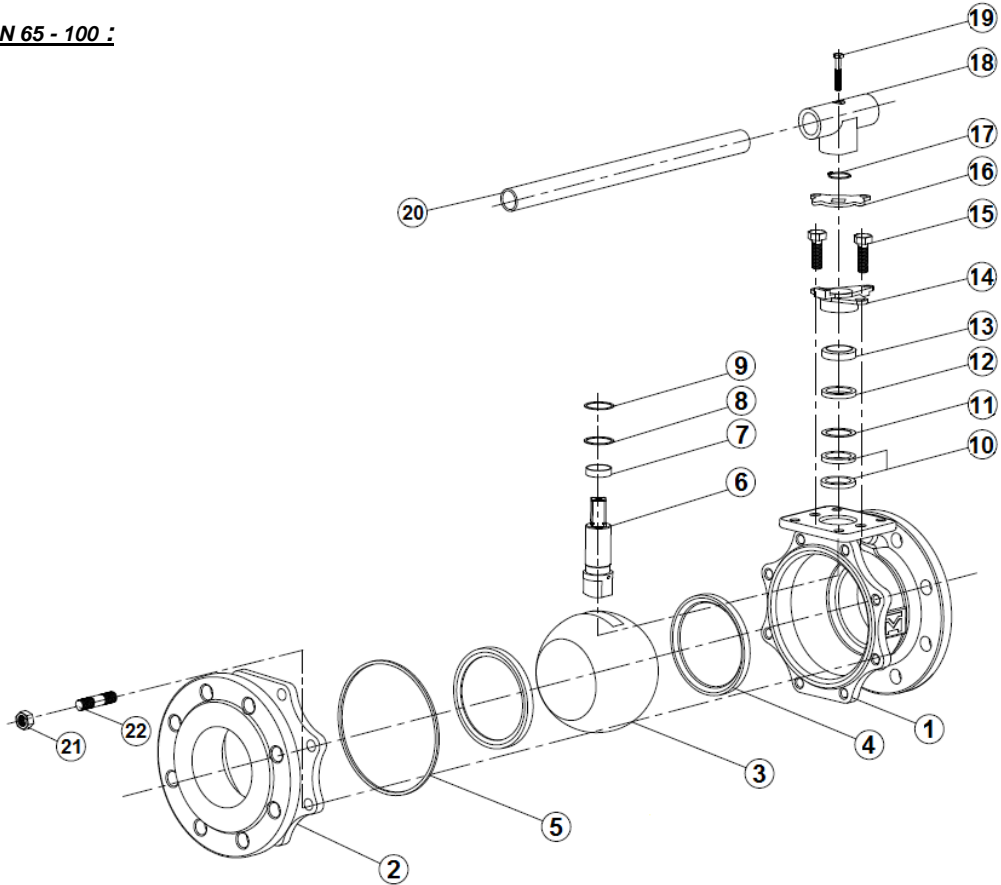

Item	Designation	Materials
1	Body	ASTM A216 WCB
2	Ends	
3	Ball	ASTM A351 CF8M
4*	Seat	PTFE filled with 15 % glass
5*	Body seal	Graphite
6	Stem	ASTM A276 316
7*	Ring	PTFE filled with 25% carbon
8*	Ring	
9*	Ring	
10*	Packing	Graphite
11*	Packing	PTFE filled with 25% carbon
12	Ring	AISI 304
13	Ring	
14	Packing gland	ASTM A351 CF8
15	Packing gland screw	AISI 304
16	Pin	
17	Circlips	
18	Handle adaptor	ASTM A351 CF8
19	Screw	AISI 304
20	Handle	
21	Nut	
22	Stud	

(* : included in gaskets kit)

**2 PIECES CARBON STEEL BALL VALVES FLANGED PN 16
PERFORMANCE RANGE**

MATERIALS DN 125 - 200 :

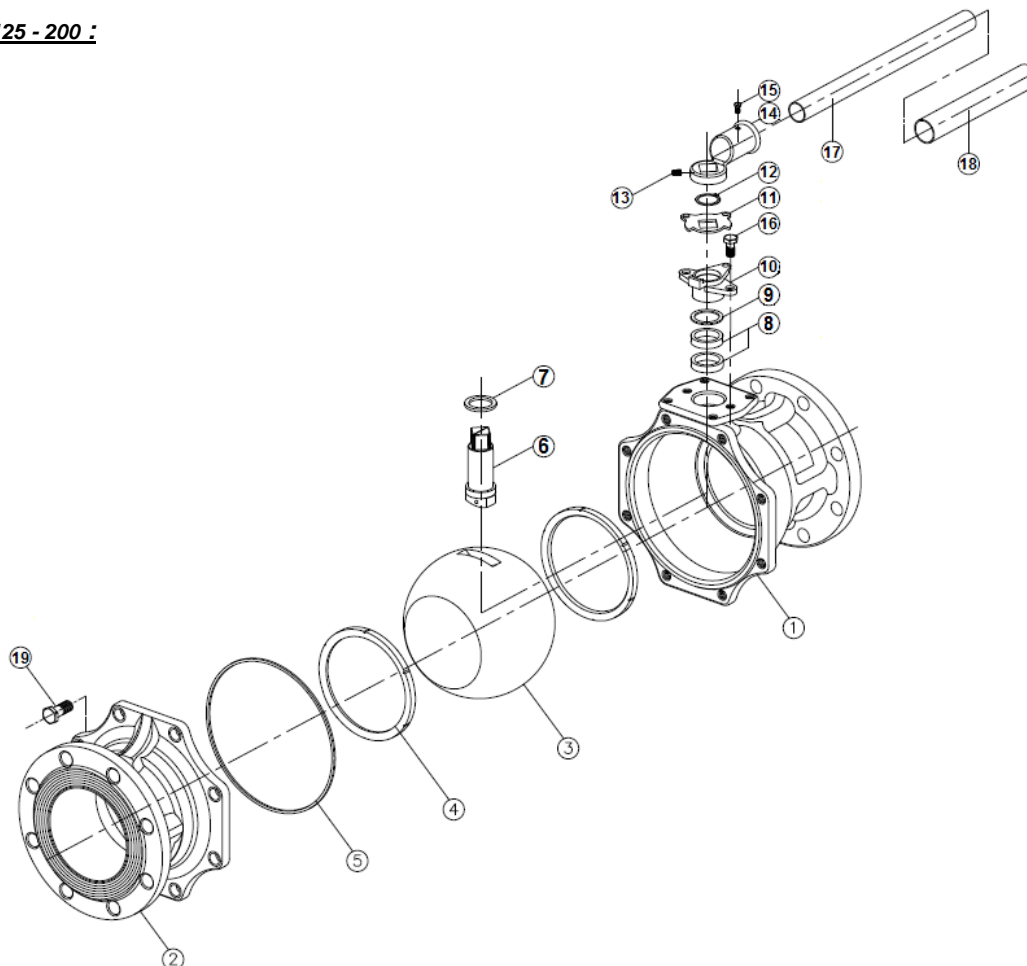

Item	Designation	Materials
1	Body	ASTM A216 WCB
2	Ends	
3	Ball	AISI 316
4*	Seat	PTFE filled with 15 % glass
5*	Body seal	Graphite
6	Stem	ASTM A276 316
7*	Ring	PTFE filled with 25% carbon
8*	Packing	Graphite
9*	Packing	PTFE filled with 25% carbon
10*	Packing gland	ASTM A351 CF8
11	Pin	AISI 304
12	Circlips	
13	Screw	
14	Handle adaptor	
15	Screw	
16	Packing gland screw	
17	Handle	PVC
18	Handle cover	
19	Body screw	AISI 304

(* : included in gaskets kit)

**2 PIECES CARBON STEEL BALL VALVES FLANGED PN 16
PERFORMANCE RANGE**

MATERIALS DN 250 :

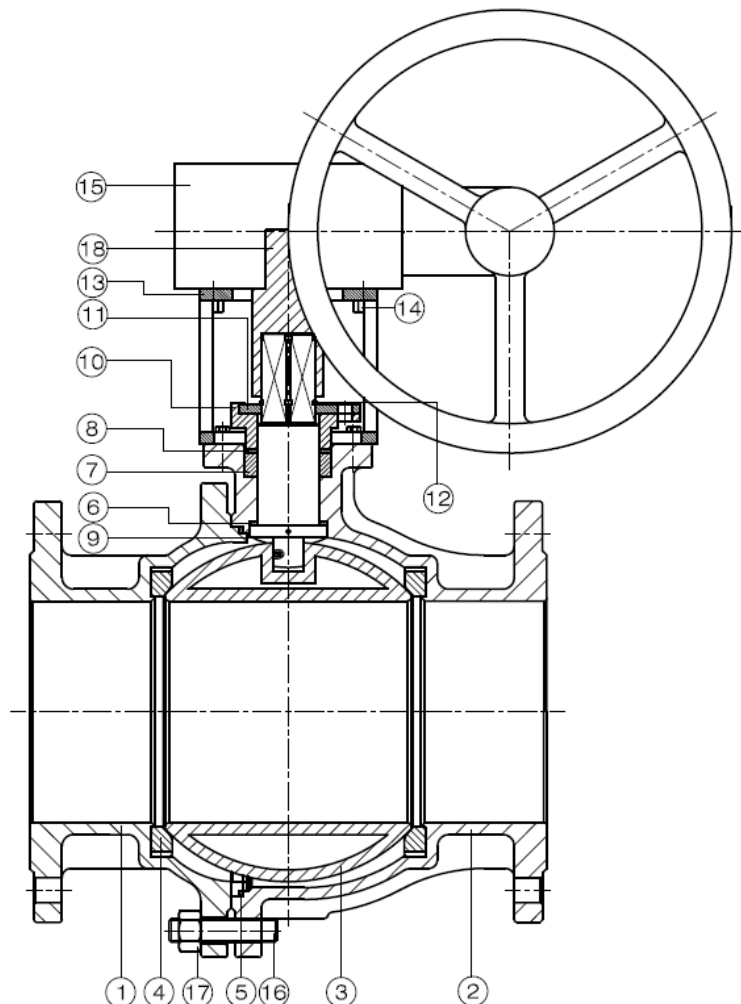

Item	Designation	Materials
1	Body	ASTM A216 WCB
2	Ends	
3	Ball	AISI 316
4*	Seat	PTFE filled with 15 % glass
5*	Body gasket	Graphite
6*	Ring	PTFE filled with 25% carbon
7*	Packing	Graphite
8*	Packing	PTFE filled with 25% carbon
9	Stem	ASTM A276-316
10	Gland	ASTM A351 CF8
11	Gland bolt	AISI 304
12	Circlips	
13	Yoke	
14	Screw	
15	Worm gear	ASTM A48-No.35
16	Stud	AISI 304
17	Nut	
18	Stem caput	SS 1045

**2 PIECES CARBON STEEL BALL VALVES FLANGED PN 16
PERFORMANCE RANGE**

MATERIALS DN 300 :

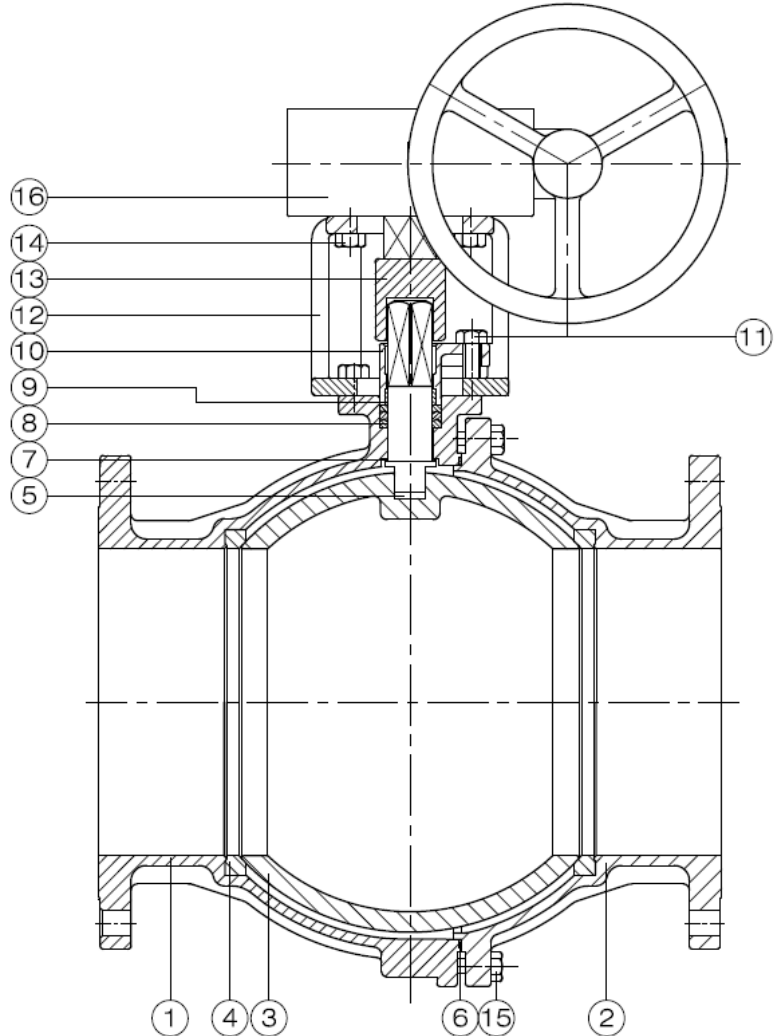

Item	Designation	Materials
1	Body	ASTM A216 WCB
2	Ends	
3	Ball	ASTM A351 CF8
4*	Seat	PTFE filled with 15 % glass
5	Stem	AISI 304
6*	Body gasket	PTFE filled with 15 % glass
7*	Ring	PTFE filled with 25% carbon
8*	Packing	PTFE filled with 15 % glass
9*	Packing	PTFE
10	Gland	ASTM A351 CF8
11	Gland screw	Carbon steel
12	Yoke	Cast iron FC20
13	Stem caput	Carbon steel
14	Yoke bolt	Carbon steel
15	Body screw	
16	Worm gear	Cast iron FC20

**2 PIECES CARBON STEEL BALL VALVES FLANGED PN 16
PERFORMANCE RANGE**

SIZE DN 15 - 50 (in mm) :

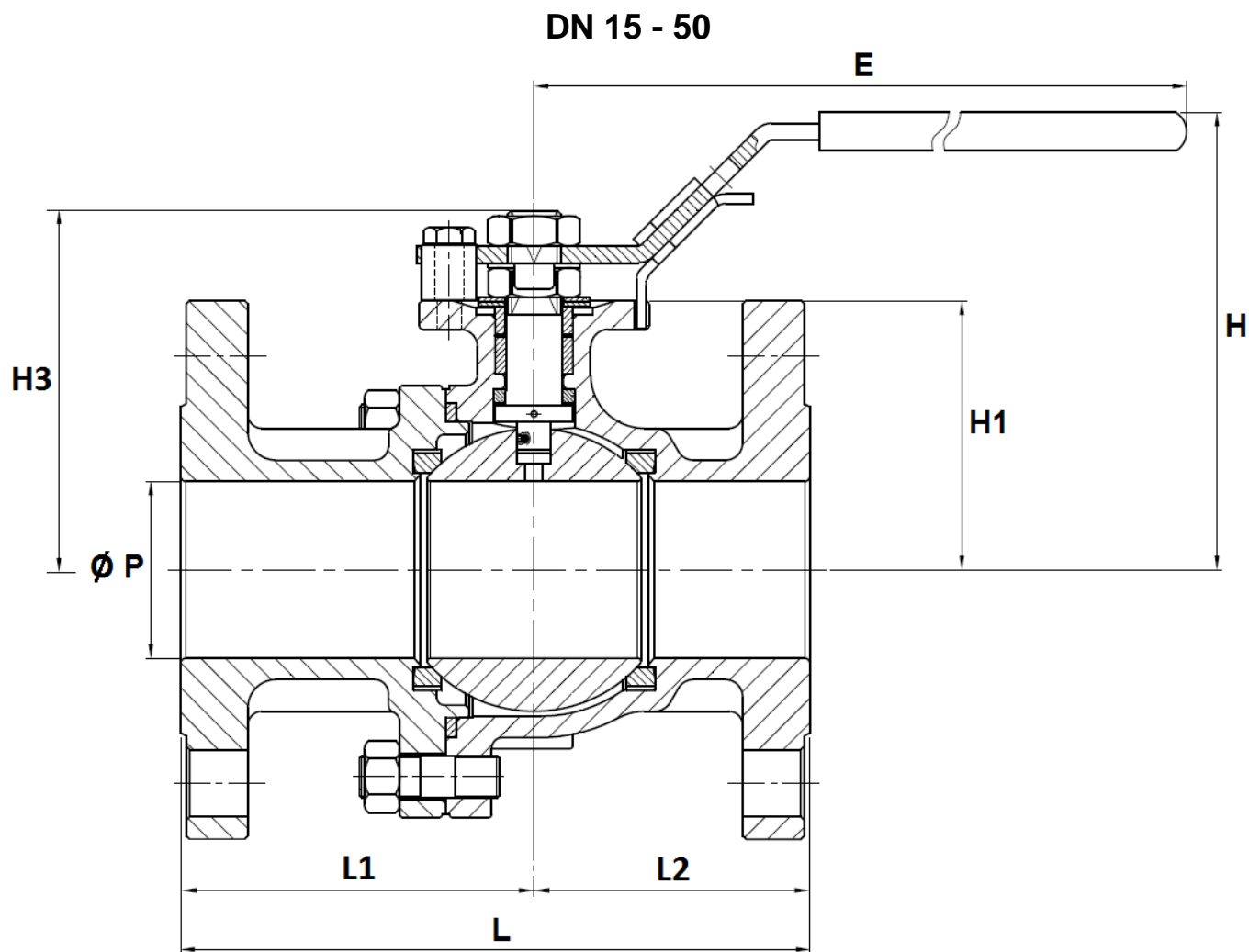

Ref.	DN	15	20	25	32	40	50
762	Ø P	15	20	24	30	38	50
	L	115	120	125	130	140	150
	L1	64.5	66.5	70.5	73	80	84.5
	L2	50.5	53.5	54.5	57	60	65.5
	E	158	158	196	196	245	261
	H	76.6	79.1	92	96	121.1	127.6
	H1	39	42.5	52	56	66	73
	H3	53.5	56.5	70	73	88	94.5
	Weight (Kg)	2.3	3	4	5.5	7	9.3

**2 PIECES CARBON STEEL BALL VALVES FLANGED PN 16
PERFORMANCE RANGE**

SIZE DN 65 - 100 (in mm) :

DN 65 - 100

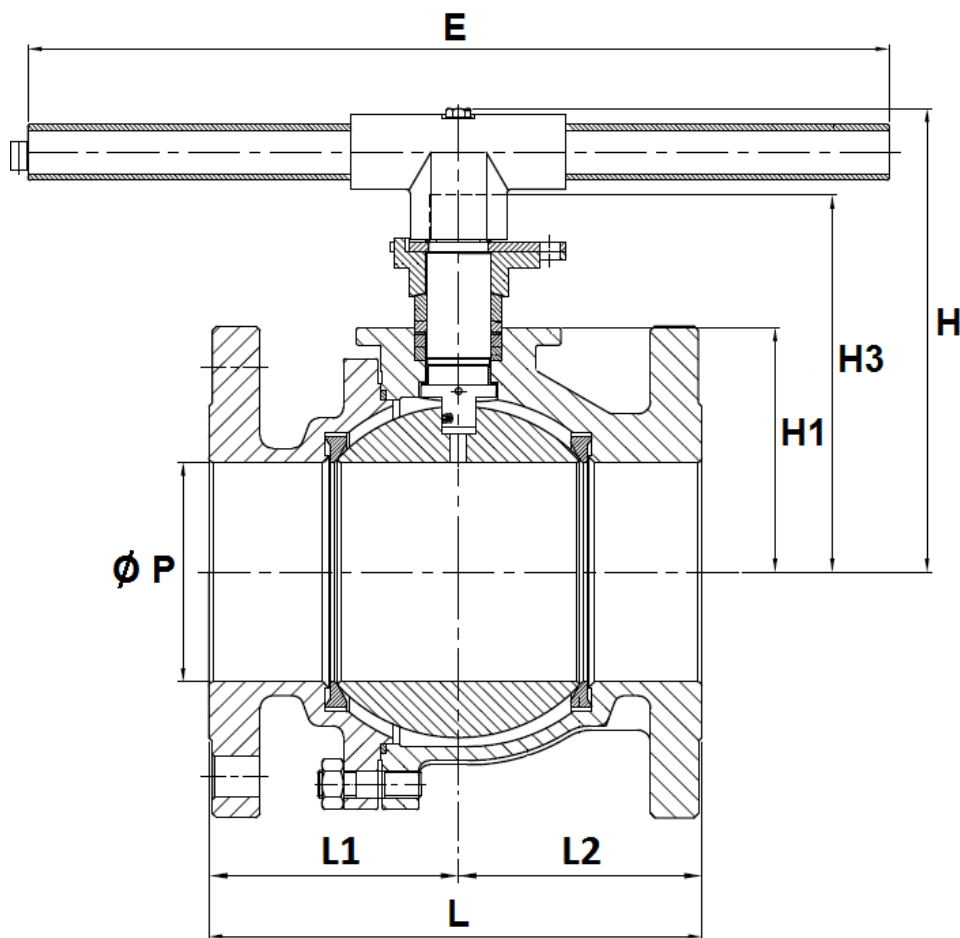

Ref.	DN	65	80	100
762	Ø P	64	76	98
	L	170	180	190
	L1	92.5	102.5	104.8
	L2	77.5	77.5	85.2
	E	400	400	400
	H	188	194	215
	H1	86.5	91.5	113.5
	H3	152	158	179
	Weight (Kg)	14.4	17.5	23.3

**2 PIECES CARBON STEEL BALL VALVES FLANGED PN 16
PERFORMANCE RANGE**

SIZE DN 125 - 200 (in mm) :

DN 125 - 200

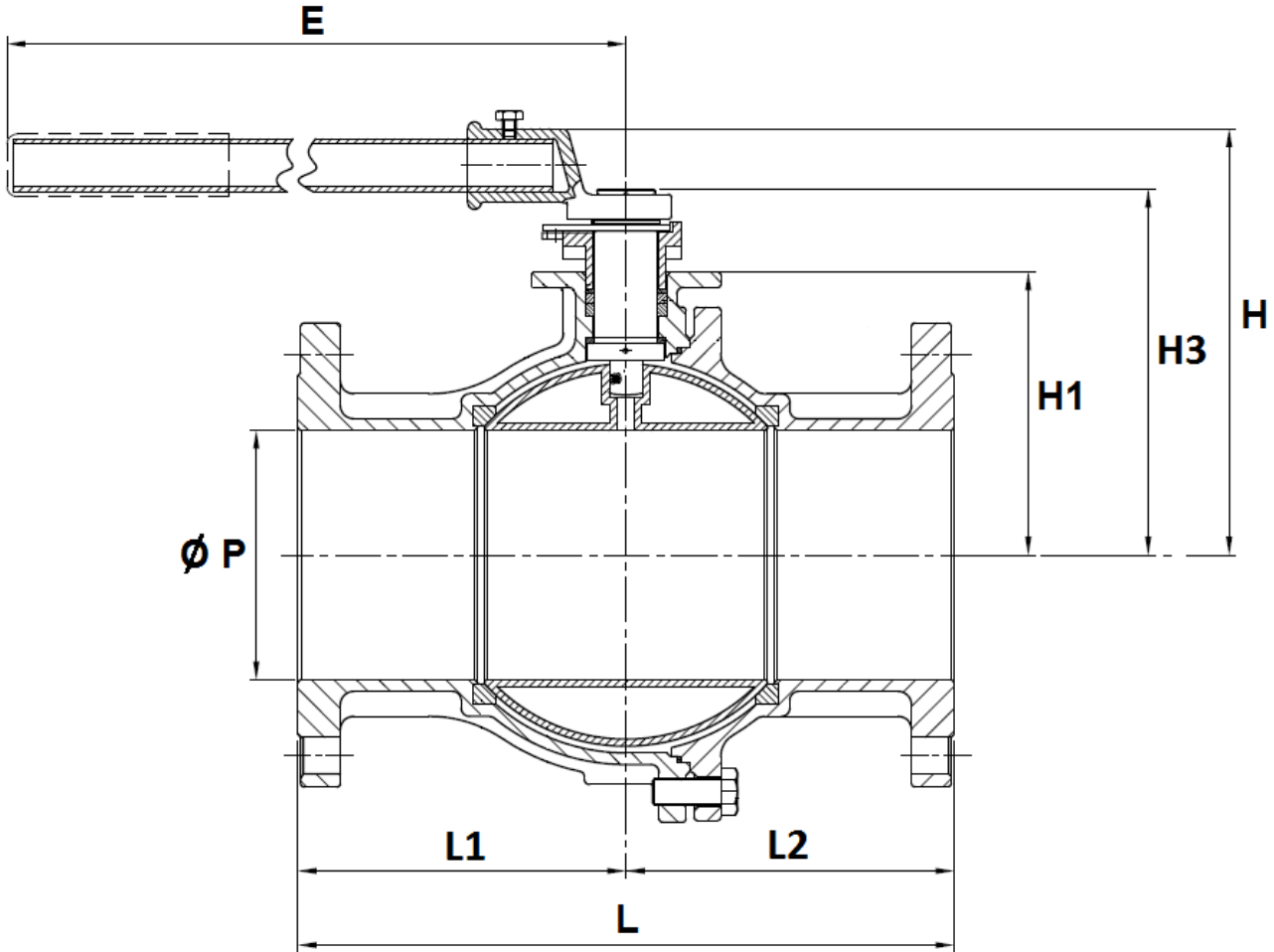

Ref.	DN	125	150	200
762	Ø P	125	150	200
	L	325	350	400
	L1	161.25	175	197
	L2	163.75	175	203
	E	743	743	925
	H	239.6	256.5	323.5
	H1	147	170	201
	H3	199	220	286.5
	Weight (in Kg)	36.7	52	78

**2 PIECES CARBON STEEL BALL VALVES FLANGED PN 16
PERFORMANCE RANGE**

SIZE DN 250 - 300 (in mm) :

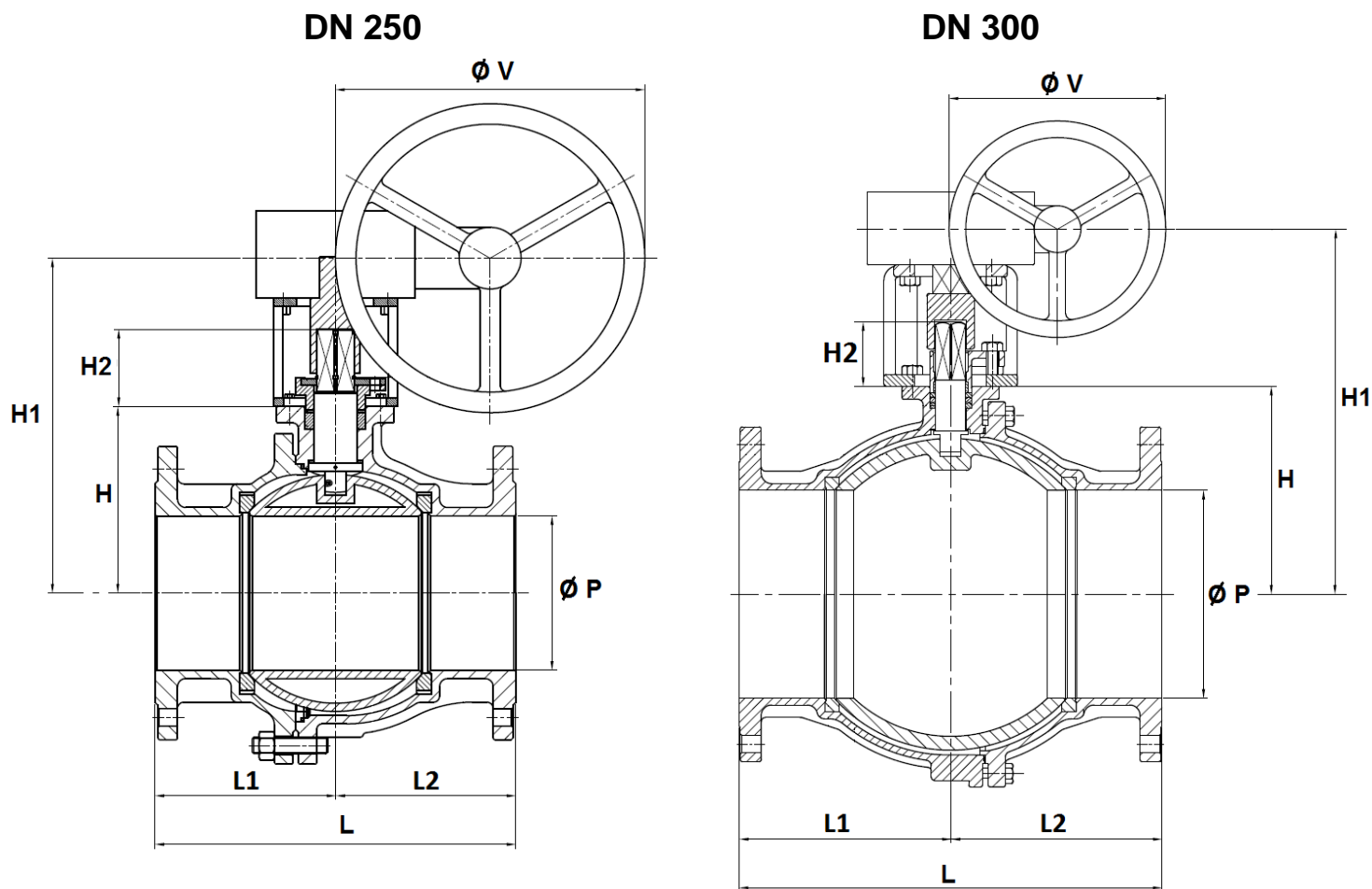

Ref.	DN	250	300
762	Ø P	250	300
	L	450	500
	L1	223.5	-
	L2	226.5	-
	Ø V	300	300
	H	260	298
	H1	393	441
	H2	85.5	85.5
	Weight (in Kg)	157	176.5

**2 PIECES CARBON STEEL BALL VALVES FLANGED PN 16
PERFORMANCE RANGE**

GEARBOX SIZE (in mm) :

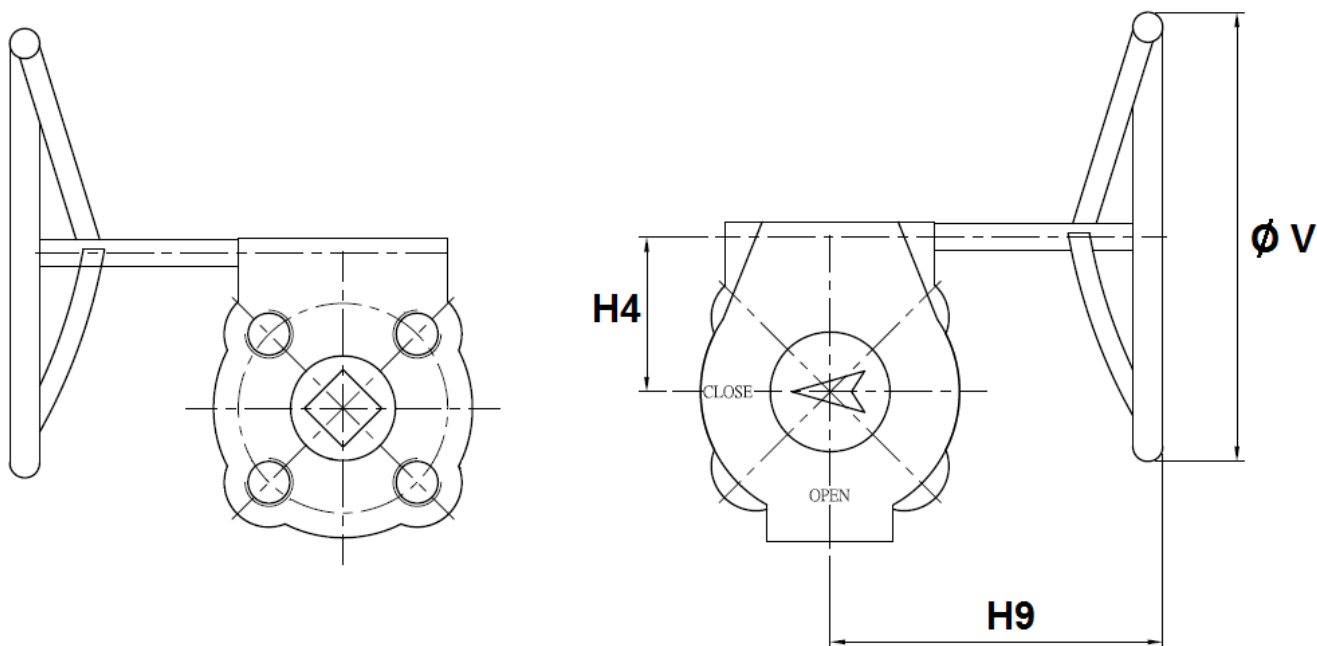

DN	150	200
H4	63	78
H9	238	226
Ø V	300	300
Weight (Kg)	12.5	15
Ref.	9830296	9830297

**2 PIECES CARBON STEEL BALL VALVES FLANGED PN 16
PERFORMANCE RANGE**

ISO MOUNTING PAD AND STEM SIZE (in mm) :

DN 15 – 50

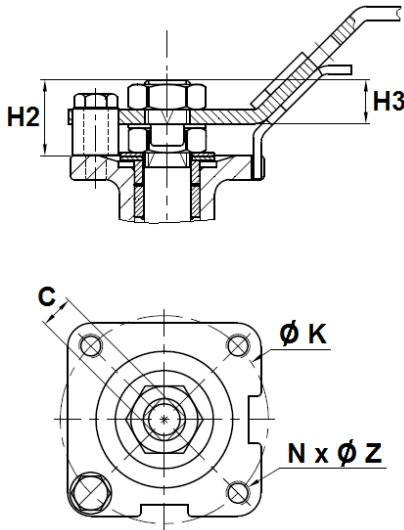

DN 65 – 100

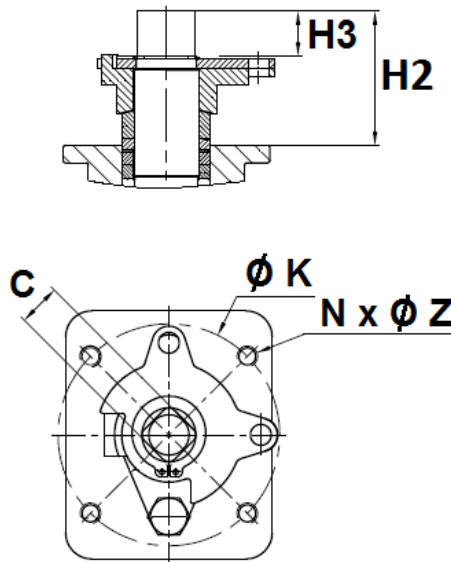

DN 125 - 300

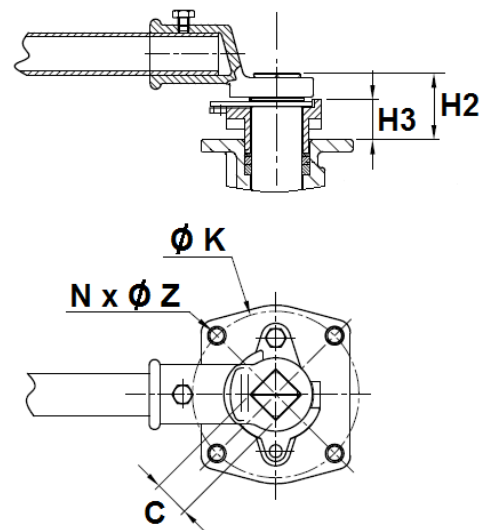

DN	15	20	25	32	40	50	65	80	100	125	150	200	250	300
C	9	9	11	11	14	14	17	17	17	27	27	36	36	36
Ø K	42	42	50	50	70	70	102	102	102	125	125	140	140	140
ISO	F04	F04	F05	F05	F07	F07	F10	F10	F10	F12	F12	F14	F14	F14
N x Ø Z	4xM5	4xM5	4xM6	4xM6	4xM8	4xM8	4xM10	4xM10	4xM10	4xM12	4xM12	4xM16	4xM16	4xM16
H2	14.5	14	18	17	22	21.5	65.5	66.5	65.5	52	50	85.5	85.5	85.5
H3	8.5	8.5	12	12	14	14	27	27	27	32	31	30	41	-

2 PIECES CARBON STEEL BALL VALVES FLANGED PN 16 PERFORMANCE RANGE

FLANGES SIZE (in mm) :

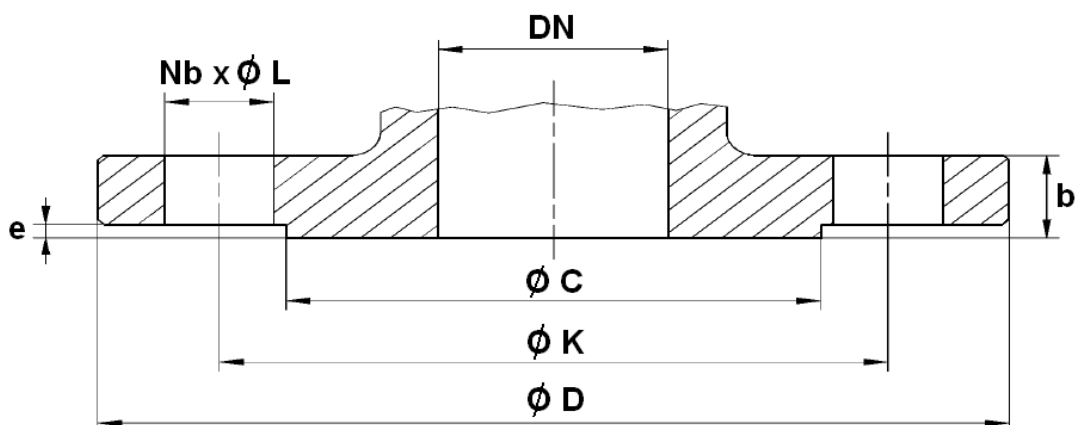

Ref.	DN	15	20	25	32	40	50	65
762	Ø C	45	58	68	78	88	102	122
	Ø D	95	105	115	140	150	165	185
	Ø K	65	75	85	100	110	125	145
	Nb x Ø L	4 x 14	4 x 14	4 x 14	4 x 18	4 x 18	4 x 18	4 x 18
	b	16	18	18	18	18	20	18
	e	2	2	2	2	3	3	3

Ref.	DN	80	100	125	150	200	250	300
762	Ø C	138	158	188	212	268	320	378
	Ø D	200	220	250	285	340	405	460
	Ø K	160	180	210	240	295	355	410
	Nb x Ø L	8 x 18	8 x 18	8 x 18	8 x 22	12 x 22	12 x 26	12 x 26
	b	20	20	22	22	24	26	28
	e	3	3	3	3	3	3	4

2 PIECES CARBON STEEL BALL VALVES FLANGED PN 16 PERFORMANCE RANGE

FLOW COEFFICIENT Kvs (M³ / h) :

DN	15	20	25	32	40	50	65	80	100	125	150	200	250	300
Kvs (m ³ /h)	31	58	86	139	229	415	698	983	1686	2824	3953	7225	7731	17994

TORQUE VALUES (in Nm without safety coefficient) :

DN	15	20	25	32	40	50	65	80	100	125	150	200	250	300
Torque (Nm)	8	10	12	20	30	40	60	90	130	160	250	500	750	1300

GEARBOX SPECIFICATIONS :

DN	150	200
Ref.	9830296	9830297
Ratio factor	30 :1	50 :1
Output torque (Nm)	700	1200

STANDARDS :

- Fabrication according to ISO 9001 : 2015
- DIRECTIVE 2014/68/EU : CE N° 0035
Risk Category III Module H
- Certificate 3.1 on request
- Construction according to EN 12516-1
- Pressure tests according to API 598, table 6
- PN16 R.F. flanges according to EN 1092-1 PN16
- ISO 5211 mounting pad
- Length according to EN 558 series 27 (DIN 3202 F4/F5)
- ATEX Group II Category 2 G/2D Zone 1 & 21 Zone 2 & 22 (optional marking)
- Fire safe according to API 607 6th Edition 2010 up to DN200

**2 PIECES CARBON STEEL BALL VALVES FLANGED PN 16
PERFORMANCE RANGE****INSTALLATION INSTRUCTIONS****GENERAL GUIDELINES :**

- Ensure that the valves to be used are appropriate for the conditions of the installation (type of fluid, pressure and temperature).
- Be sure to have enough valves to be able to isolate the sections of piping as well as the appropriate equipment for maintenance and repair.
- Ensure that the valves to be installed are of correct strength to be able to support the capacity of their usage.
- **Installation of all circuits should ensure that their function can be automatically tested on a regular basis (at least two times a year).**

INSTALLATION INSTRUCTIONS :

- **Before installing the valves, clean and remove any objects from the pipes** (in particular bits of sealing and metal) which could obstruct and block the valves.
- **Ensure that both connecting pipes either side of the valve (upstream and downstream) are aligned (if they're not, the valves may not work correctly).**
- **Make sure that the two sections of the pipe (upstream and downstream) match, the valve unit will not absorb any gaps. Any distortions in the pipes may affect the tightness of the connection, the working of the valve and can even cause a rupture.** To be sure, place the kit in position to ensure the assembling will work.
- **If sections of piping do not have their final support in place, they should be temporarily fixed. This is to avoid unnecessary strain on the valve.**
- Tighten the bolts in cross.
- It's recommended to operate the valve (open and close) 1 to 2 times per year